

OPERATION OF THE TISCH ENVIRONMENTAL 3 – CHANNEL CANISTER SAMPLER

Operator's Manual



Table of Contents

	<u>Page No.</u>
1.0 OPERATION OF TISCH ENVIRONMENTAL 3-CANISTER SAMPLER	
1.1 General Discussion	3
1.2 Sampling Equipment	5
1.2.1 Sample Pump	5
1.2.2 Sample Inlet Line	5
1.2.3 Particulate Inlet Filters	5
1.2.4 Stainless Steel Vacuum/Pressure Gauges	5
1.2.5 Adjustable Micro metering Valve	6
1.2.6 Idec Operator Panel	6
1.2.7 3-way Solenoid Valves	6
1.2.8 Tubing and Fittings	6
1.2.9 Water Traps	6
Figure 1 3-canister flow diagram	7
1.3 Sampling Procedure	8
1.3.1 General Discussion	8
1.3.2 Detailed Procedures	9
1.3.3 Sampler Shutdown	20
Figure 2 Canister Sampling Log Sheet	22

1.0 OPERATION OF THE 3-CHANNEL CANISTER SAMPLER

1.1 General Discussion

The **TISCH** 3-canister Sampler takes air from the inlet on the pump and injects it into the canisters at a constant flow rate for a preset time. The excess air is released through the bypass exhaust. The constant flow rate and elapsed time allow the operator to compute the volume of the integrated air samples. The samples are pumped through a Stainless Steel, Teflon diaphragm, 12 volts DC pump, which develop sufficient pressure to control the flow with a regulator. The pump also samples the air at a flow rate (5 L/min) to keep any long sampling line flushed. A small, constant flow of sampled air is pumped into the sample canisters. The sampler will operate on 12 volts DC through a molex plug on back of sampler. The pointed end of the plug is positive (+) and the flat end is negative (-), and draws 5 amps. **(ALWAYS USE A 5 AMP FUSE INLINE ON THIS 12V.D.C. INPUT)** The a/c cord will take an input of 100-240 volts AC at 2 amps.

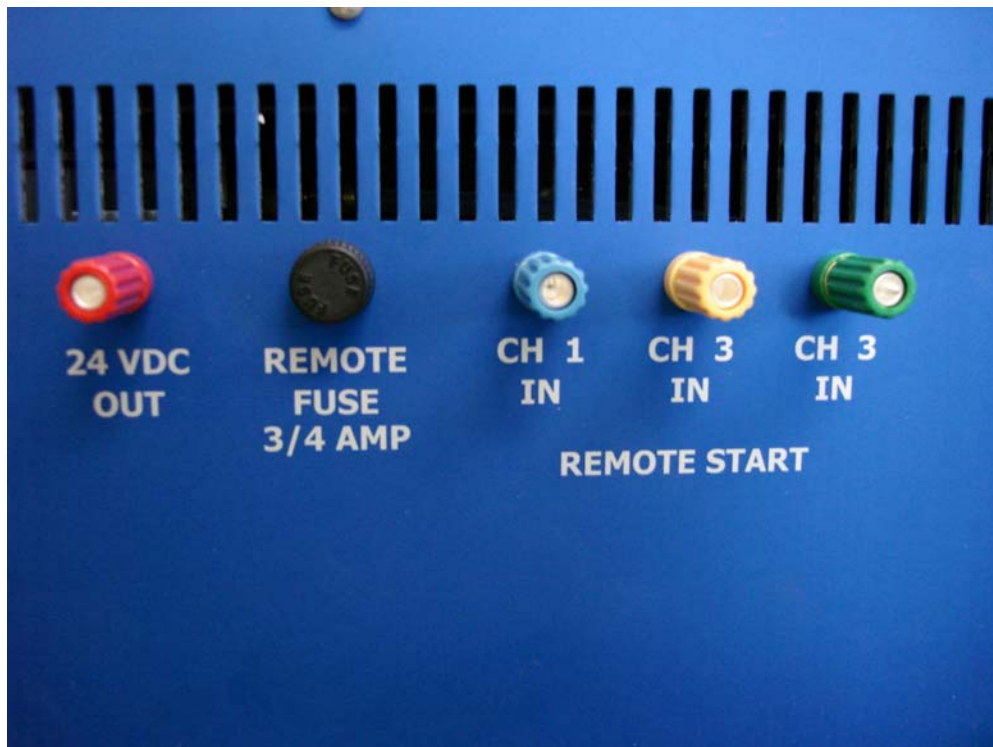
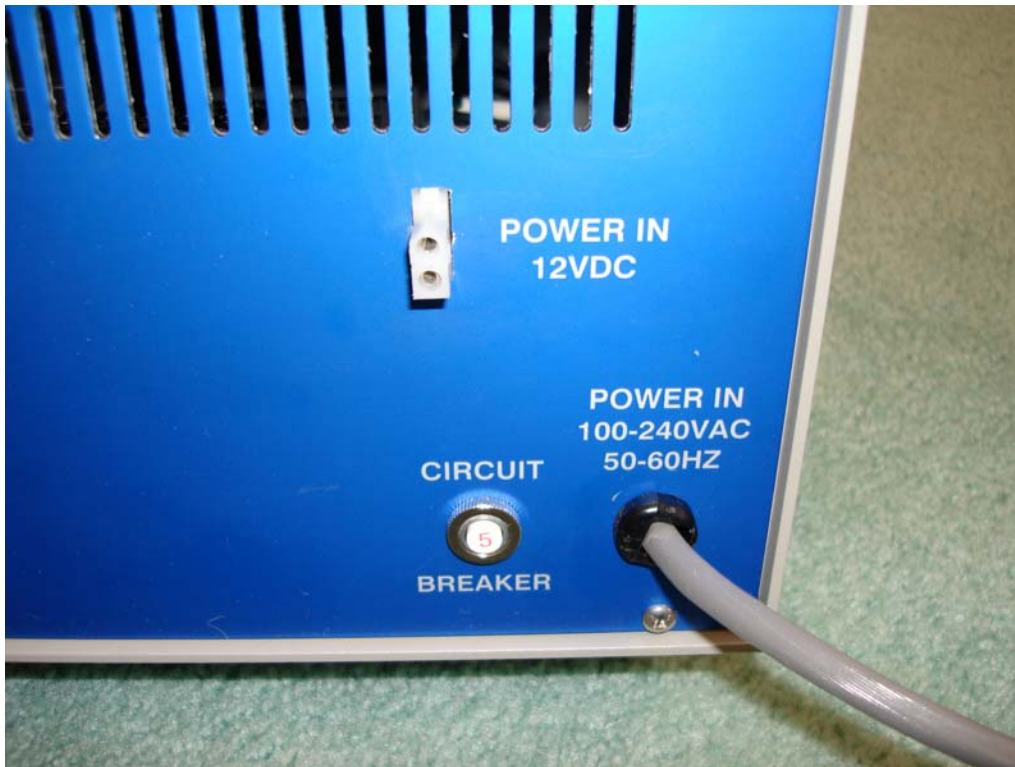

The sampler also has a remote start feature. Use four (4) wire conductors, and connect one wire to 24 volt d/c outlet and the others wires to each of the Ch-1, Ch2, and Ch-3 In. On the data logger side use a relay control output and put these cables on each side of the open relay, and loop the 24 volts DC to the other side of the open relays. When the data logger

closes the open relay for the channel needed the sampler will start and the front panel will record the run time.

NOTE: If the backpressure is set too high, the sampled airflow will be too low to flush the sample line. The back pressure should be set at 18 psi.

Following sampling, the pump turns off and the solenoid is shut off and the check valve seals the canister until an operator can close off the canister valve. The canister should also be sealed with a 1/4" Swagelock or Parker A-LOCK cap after the canisters are removed.

1.2 Sampling Equipment

1.2.1 Sample Pump

The sampler uses one 12 volt DC stainless steel Teflon diaphragm, capable of 2 atmospheres output pressure. The pump must be free of leaks and determined to be nonbiasing. The pump can deliver up to their maximum pressure (~ 30 psi). A needle valve is located in the exhaust stream of the pump. The pressure gauge is located just upstream of the valves. By throttling the valve, the pressure is increased. Although it is not necessary to maintain a constant exhaust flow rate or pressure, it is necessary to keep the pressure 3 psi above your final canister pressure, in order for the flow regulator to function properly. It is also necessary to keep the exhaust flow rate relatively high to allow sufficient sample to be drawn through the sample line. A setting of 3 to 5 psi above the final canister pressure provides the best operation pressure.

1.2.2 Sample Inlet Line

Chromatograph-grade stainless steel or Teflon tubing is used to connect onto the inlet pre-filter on the sampler. The opposite end connects to a sampling probe or manifold assembly.

1.2.3 Particulate Inlet Filters

The inlet prefilter is attached to the pump inlet. A 47mm round glass fiber filter is used inside the filter holder to trap particulates p/n **TE-G653-47**.

1.2.4 Stainless Steel Vacuum/Pressure Gauges

These are capable of measuring vacuum (0-30 inches Hg) and pressure (0-30 psi). The gauge should be leak-free and shown to be nonbiasing.

1.2.5 Adjustable Micrometering Valve

The flow regulator measures and controls the flow of sample air. This eliminates the need for continuous monitoring and readjustment of air pressures to provide a stable gas flow. The regulator is capable of maintaining a constant flow rate ($\pm 2\%$) over a specific sampling period under conditions of changing temperature (20-40 °C) and humidity (0-100% relative). It is important to have the right flow element for the run time. Contact Tisch Environmental to determine the correct flow element. For a flow to fill a 6 L canister in 24 hours a 144 flow element is needed and is provided as a standard. This will give you flow adjustments in increments of 1 sccm to 55 sccm and will give you an adjustable flows in $1/10^{\text{ths}}$ of a sccm.

1.2.6 Idec Operator Panel

This panel is used to control the Idec programmable controller. It lets the operator scroll through the preprogrammed menu to control the on and off times of pump and samples. It also allows the operator to set the days of the week on which the sampling will take place and it will keep the total run time for each sample run.

1.2.7 1 (3-way) Solenoid Valve

The sampler has one 3-way 12 volt DC electric-operated stainless steel solenoid valve, with Viton® plunger seat and O-rings.

1.2.8 Tubing and Fittings

All tubing in contact with the sample prior to analysis should be chromatographic-grade stainless steel and all fittings should be 316 grade stainless steel.

1.2.9 Water Traps

The water trap is on the front panel, next to the exhaust port. The trap should be emptied on each site visit.

TISCH ENVIRONMENTAL

FIGURE 1

3-CANISTER FLOW DIAGRAM

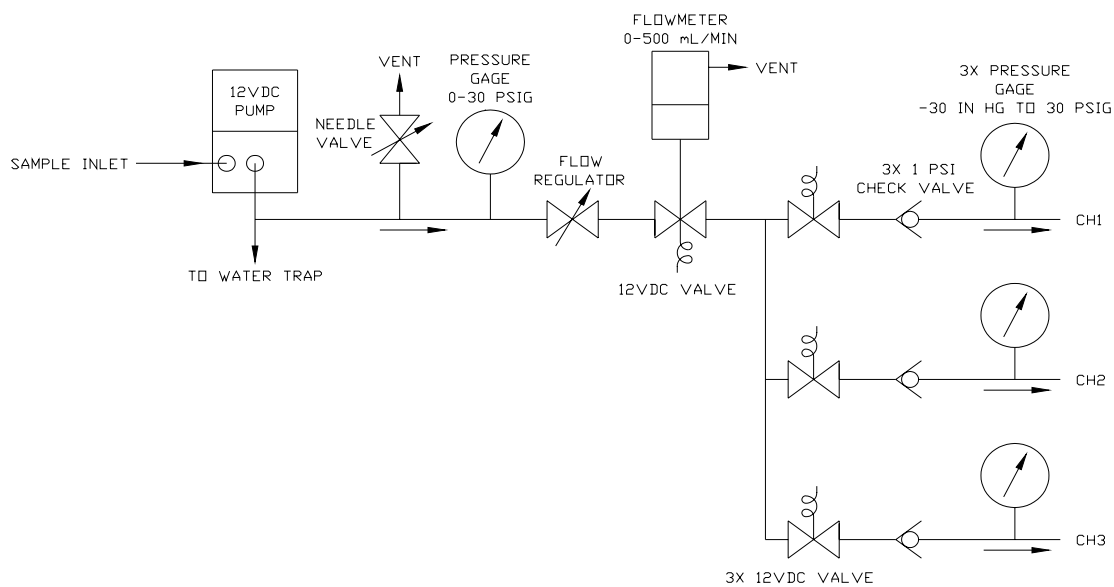

1.3 Sampling Procedure

1.3.1 General Discussion

The sample is collected into one canister using one pump and flow control device. Flow control device is used to maintain constant sample flow rates into the canisters over a specific sampling period. The flow rate used is a function of the final desired sample pressure and the specified sampling period and assumes that the canisters start at a pressure of 5 mmHg absolute. The flow rates can be calculated by:

$$F = \frac{P \times V}{T \times 60}$$

where: F = flow rate (ML/min)

P = final canister pressure (atmospheres Absolute)

V = volume of the canister (mL)

T = sample period (hours)

60 = minutes in an hour

For example, if a 6-L canister is to be filled to 2 atmospheres absolute pressure in 3 hours, the flow rate can be calculated by:

$$F = \frac{2 \times 6000}{3 \times 60} = 67.7 \text{ mL / min}$$

For automatic operation, the timer is programmed to activate and deactivate the sample collection system at specified times, consistent with the beginning and end of a sample collection period.

1.3.2 Detailed Procedures

The following provides specific details for operating the 3 Channel Canister sampler.



With the power turned on, the front control panel shows the Tisch logo. The bottom part of the screen will give you the phone number if you need information on the sampler. Touching the ENTER area of the screen will take you to the next page.

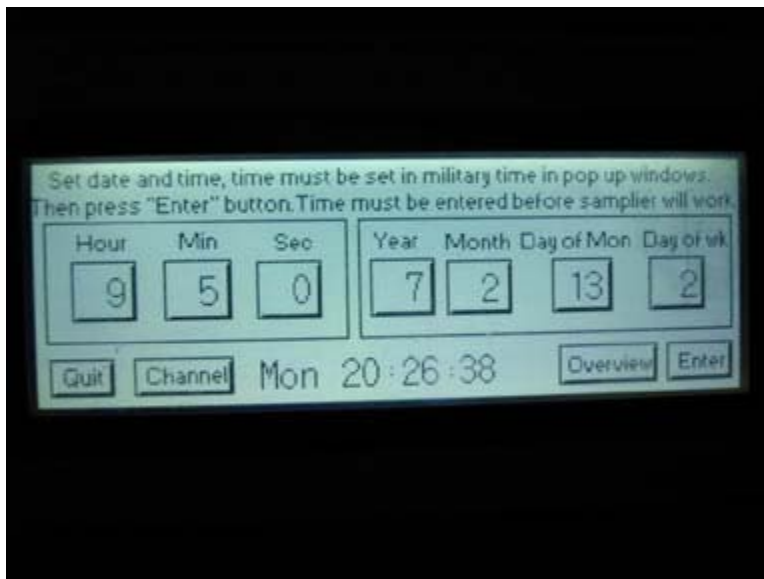

This is where the site time. Month, day, year, and day of the week is installed. When entering this information, leave your self two extra Minutes of time to finish entering information, then enter when the time is correct. Once this is installed, make sure you do not touch the enter button a second time. Touching the ENTRE button will reenter what is shown on the screen.



To enter the hour, touch the hour area and the number menu will appear. Touch the hour and then touch ENT on the menu.



To enter the set minute, touch the Min area and the number menu will appear. Touch the Minutes and then touch ENT on the menu.



To enter the seconds, touch the Sec area and the number menu will appear. Touch the Seconds and then touch ENT on the menu.



To enter the Year, touch the Year area and the number menu will appear. Touch the Year and then touch ENT on the menu.



To enter the Month, touch the Month area and the number menu will appear. Touch the Month and then touch ENT on the menu.



To enter the Day of the Month, touch the Day of Mon area and the number menu will appear. Touch the day of the Month and then touch ENT on the menu.

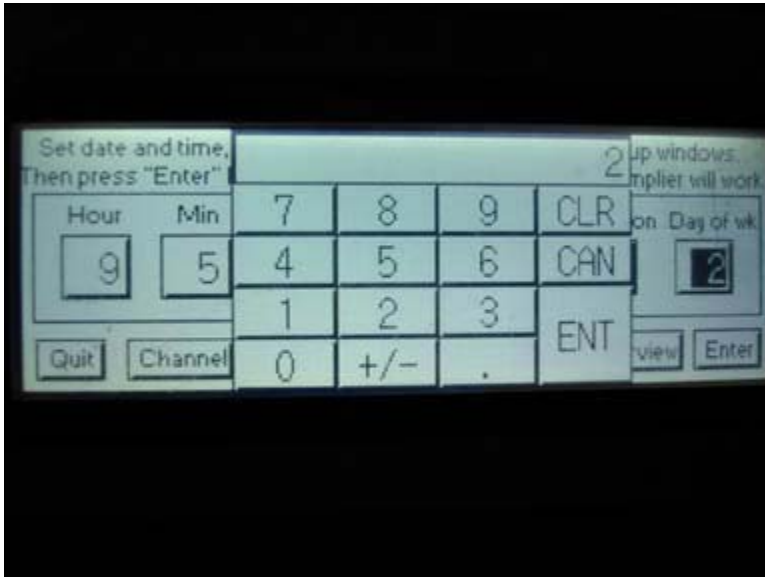

To enter the Day of the Week, with Monday being day one, touch the Day of Week. area and the number menu will appear. Touch the day of the Week and then touch ENT on the menu.

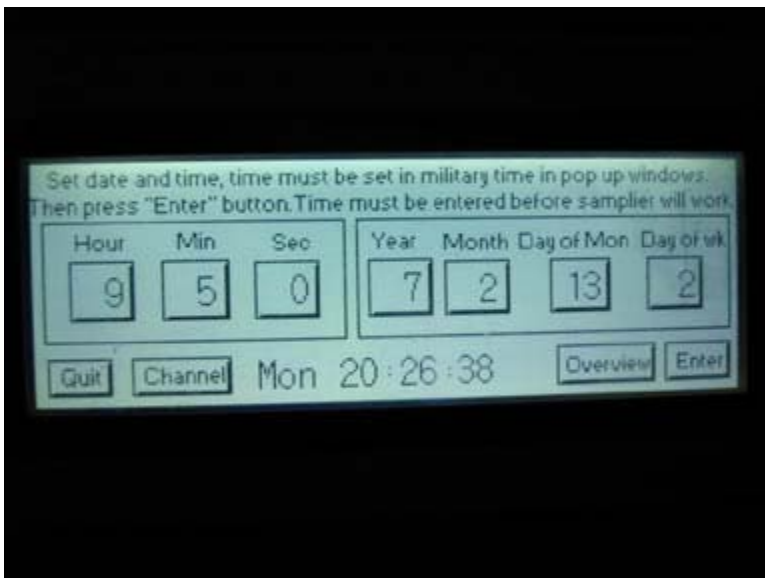

Now with everything entered into the touch screen, touch the Enter button in the lower right corner. You should see the day of the week and time change in the bottom center of the screen. Remember not to touch this Enter button again or it will reenter this information. Now touch the Channel button, lower left corner.

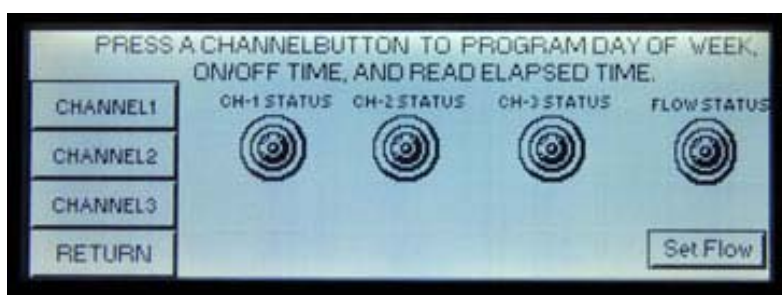

If you are running the sampler on the bench, make sure the inlet filter is installed, to keep dust or dirt from going into the sampler.

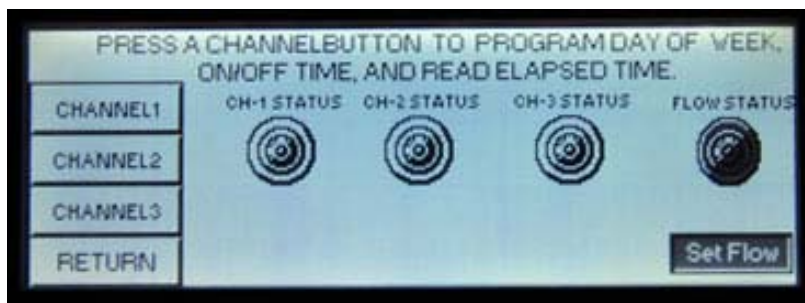

Touch the set flow, and the pump will start, and the flow read out will show flow on the front panel. Set the back pressure at 18 psi and then adjust your flow for the time of your run. When the back pressure is set to the 18 psi the flow regulator will have to be readjusted. They both work together and once balanced out the flow will stay at its set point. **NOTE: there is a 3 Minute timer and the SET FLOW button and the pump will go off, or if you touch the SET FLOW**

button again it will turn off the pump. So if you need more time to set the flow, press the set flow button again.

To set the run time, touch the Channel number button your need to set



Start with setting the on time, touch the Start Time area and this menu will appear.

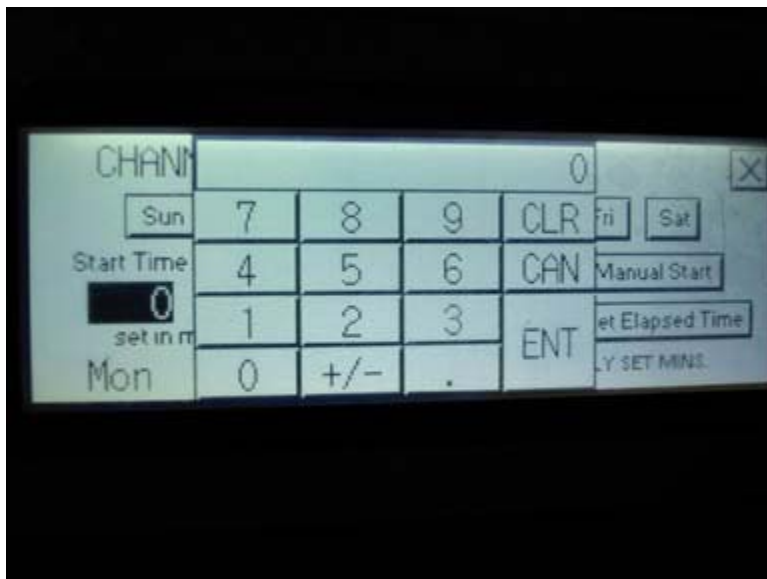

To enter the Start Time, touch the Start Time area and the number menu will appear. Touch the Start Time in. **Remember this is a 24 hour clock** set the hour and minutes if needed, other wise 00 and then touch ENT on the menu. For midnight 12 AM just enter 0 and only minutes until 1:00AM.



To set the day of the week you want the sampler to run, just touch the day and it will show dark (on) in the area. Touch it again and it will turn off.



To manually start button menu lets you start and stop the sampler on that channel manually, and the Reset Elapsed timer puts the timer back to 0.



To enter the Stop Time, touch the Stop Time area and the number menu will appear. Touch the stop time and then touch ENT on the menu. Go through the same steps as the on time, installing the day of the week and stop time. One thing to remember, if you are starting at midnight and run 24 hours, using Wednesday for example. You would set Wednesday for the start time and Thursday for the off time and setting the time at 0 hours on both.



Touch the Stop button lets you stop a run that was started with the timer with out having to set an off time to stop the sampler. There is a one Min. delay if the sampler started with set on time. After one Min. the sampler can be turn off right away. This button is also a reset button if touched would reset the PLC and cancel the set time.

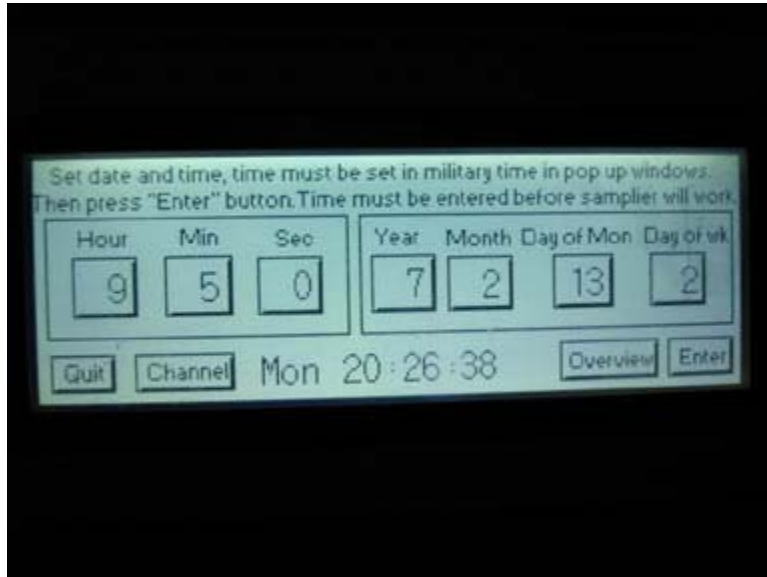

Touch the Overview button when the sampler is in use and it will show the status of the sampler.

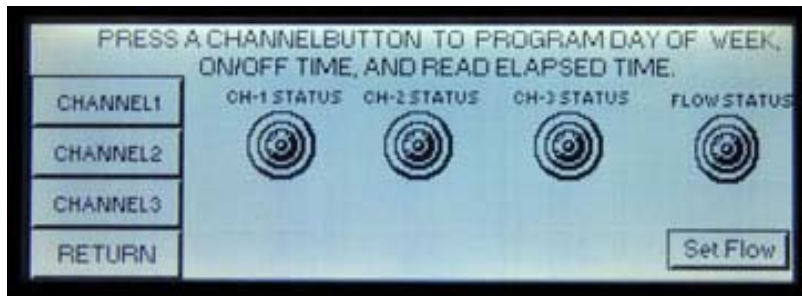

Touch the RETURN and it will take you back to the main menu.

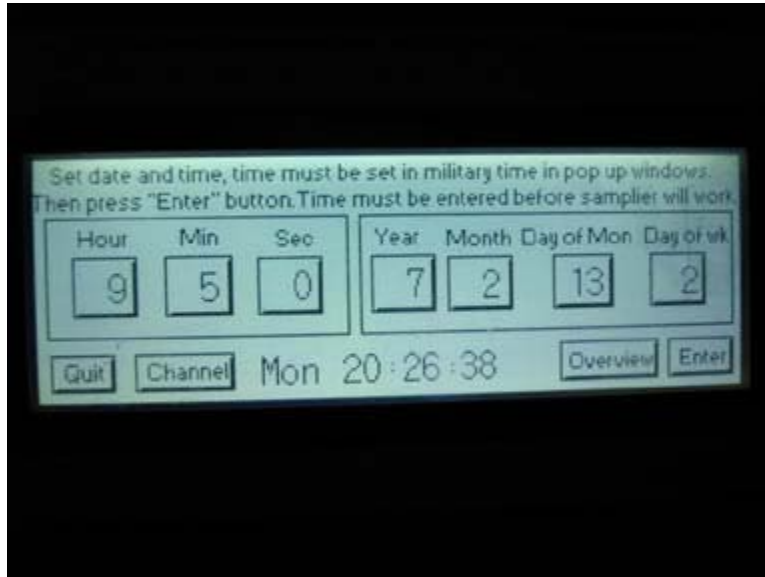

Touch the Quit button and it will take you back to the Tisch menu.



The following provides specific details for operating the 3-Channel Canister Sampling System.

- ① Verify the correct sample flow rate by using the calibrated mass flow meter inside the sampler. The sampling system is manually activated on the Idec Touch Panel. Turn on the pump. Adjust the flow rate for the run time.
- ② Deactivate the sampler and reset the elapsed times indicated on the Idec Touch panels.
- ③ Disconnect the cap on sampling port and attach clean canisters to the sampling ports.
- ④ Open the canisters' bellows valves.
- ⑤ Record the initial vacuum in the canisters, as indicated by the sampling system's vacuum gauge, on the canister sampling field data sheet.
- ⑥ Record the time of day and date the samples are going to run on the canister sampling field data sheet. Set the Idec Touch Panel times that the sample will start and stop and reset the total run times. (See instructions, above, on how to set Idec Touch Panel). After sample collection, record the final sample pressures on the sampling field data sheet. The final sample pressures should be close to the desired calculated final pressures. The time of day and elapsed time indicator readings should also be recorded on the sampling field data sheet.

Close the canister bellows valves. Disconnect and remove the canisters from the sampling system. Fill out the identification tag on the canister. The canister serial number, sample date and location should be recorded on the tag in case log sheet is lost.

1.3.3 Sampler Shutdown

- If high humidity is prevalent at the time of sampling, the water traps should be emptied. Remove the caps and place the caps on the exhaust ports. If shelter temp is below 76 F and the outside temp is over 80 F, water may be in trap. Try to keep back-pressure 2 psi above the

final canister pressure to reduce water in sampler. Also keep sample line insulated or heated inside shelter to sampler.

- Start the pump. Do not turn on the channel, as this might force water through the flow regulators. Reach down to the water trap opening and place finger over the port. Let the pressure build up to maximum, then let your finger slide off the water trap port. This will force water in the tubing to flow out of the system.
- Carry out this procedure about 10 times on each port.

When the water trap is empty, turn off the pump and place the cap back onto the water trap port. Then turn the power off. The operator must install all caps on the sampler's open ports to keep the sampler clean.

CANISTER SAMPLING LOG SHEET

PROJECT:
Account No.

Canister Sampler

Canister I.D.: _____ Sampler I.D.: _____

Sample Location (Site): _____

Sampling port number: _____

Sample Date: _____

Sample Time: Start: _____ Stop: _____

Elapsed Time: Start: _____ hrs. _____ Mins.

Stop: _____ hrs. _____ Mins.

Flow Rate (cc/min): Start: _____ Stop: _____

Back Pressure (psi): Start: _____ Stop: _____

Canister Pressure (psi): Before: _____ After: _____

Temp and Atm Pressure: Before: _____ After: _____

Checks before Sampling:

Power Supply On:
Timer Program Installed:
Canister Valve Open:

Checks during Sampling:
Red and Green Lights on Timer:
Pump Running and Showing Back Pressure:

After Sampling:
Close Canister Valve before Removing:

Comments:

Operators: Start: _____ Stop: _____

Figure 3. Example Canister Sampling Field Data Sheet.