



*737-15 Pictured

737-14 (100 SLPM)

737-15 (250 SLPM)

Models	737-14, and 737-15
Zero Air Grade	Ultra Zero Air
Flow Rate Maximum	250 SLPM @80psi
Purification Technologies	PSA and Heated Catalytic Reactor
Purity Specifications	So ₂ < .5 ppb H ₂ S < .5 ppb NO < .5 ppb NO ₂ < .5 ppb NH ₃ < .5 ppb O ₃ < 1 ppb CO < 1 ppb Hydrocarbons < .0005 ppm (Methane and Non-Methane)
Dewpoint	-50 °C
Electrical Requirements	115V, 60Hz (15A circuit) or 220-240V, 50/60Hz
Warranty	1 Year
Dimensions (HxWxD)	21" (533mm) x 18.25" (464mm) x 28" (711mm)
Weight	737-14 145lbs (319kg) 737-15 180lbs (396kg)

*no internal compressor

The 737 series of generators are a family of highly efficient ultra-zero air generator that convert ambient air to pollutant-free ultra-pure zero air. The unit employs a heated catalyst for hydrocarbon and CO removal and a pressure swing absorption system for contaminant and optional CO₂ removal. The 737 series instruments are special in the fact that they are able to produce such a high volume of zero air with such consistency. The 737 can be used in a variety of applications for the reliable generation of ultra-zero air.

Flow Diagram

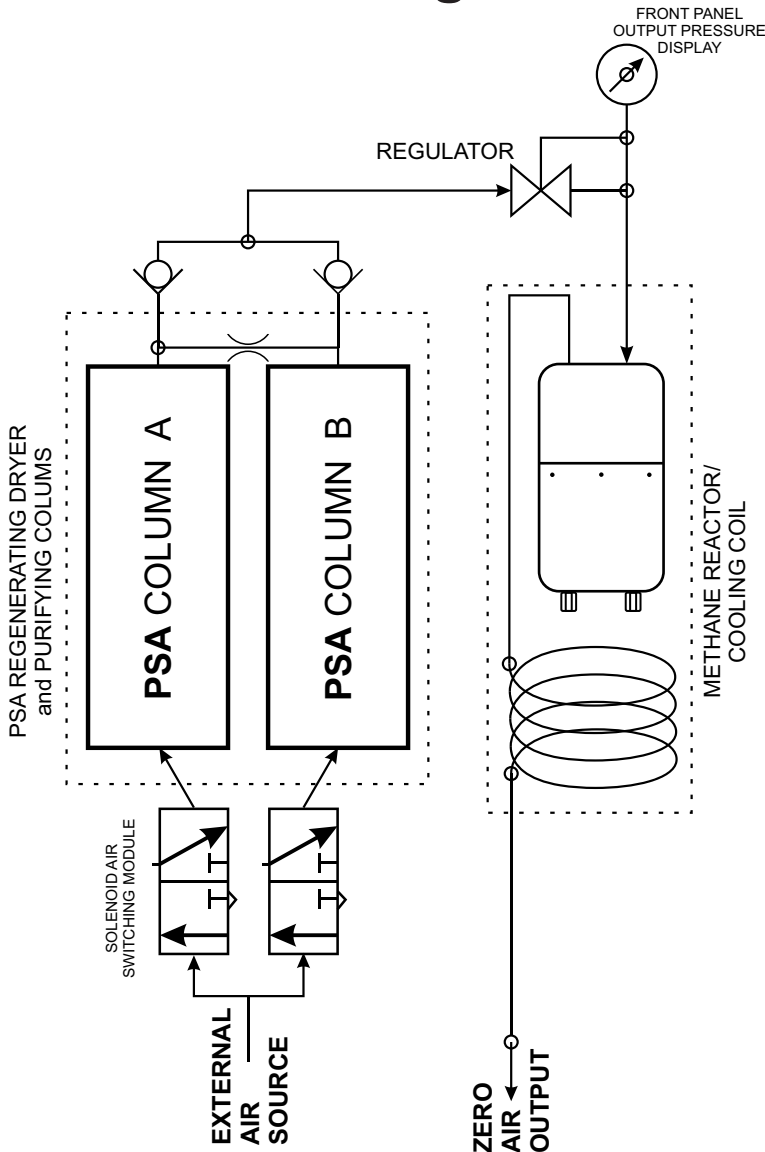

Industries and Applications

- Automotive emission monitoring
- Gas Chromatography
- Oil and Natural gas
- Aerospace
- Laboratory instrumentation
- Calibration and Certification
- Environmental gaseous instrumentation
- Ultra-zero air generation
- Reliable generation of ultra-high purity zero air
- Economical replacement of zero air bottles

737 Series Part Number Matrix

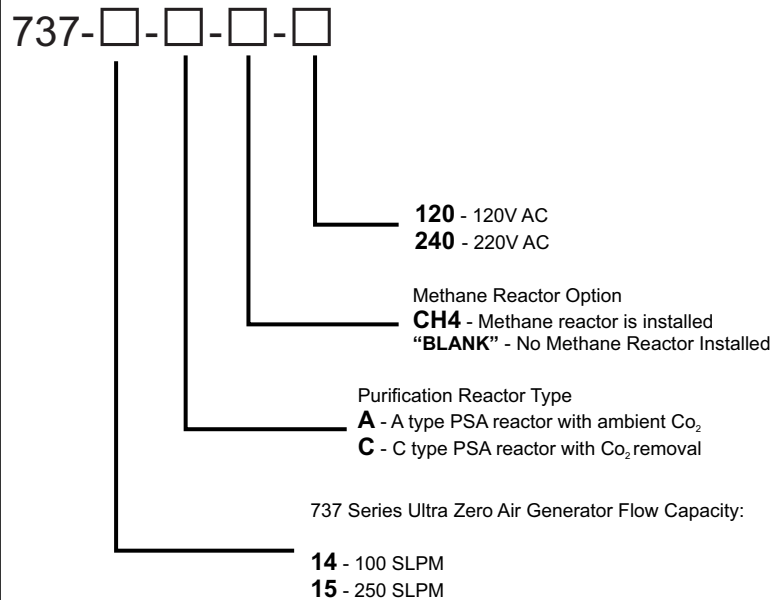

Example: 737-15-A-CH4-120

250 LPM Ultra Zero Air Generator with ambient CO₂ output, Methane removal reactor, and 120V operating voltage

*no internal compressor